

SS/SN MULTISPRING PUSHER SEAL

- UNITIZED COMPRESSION UNIT
- BIDIRECTIONAL ROTATION
- FITS ON ANSI & ISO PUMPS
- AVAILABLE IN METRIC SIZES AS PER EN 12756
- APPLICATION SPECIFIC DESIGN VARIATIONS FOR DIFFERENT NEEDS

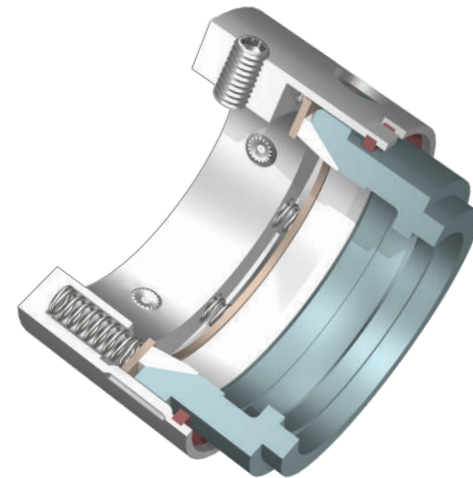

APPLICATIONS :

- CLEAR AND LUBRICATING MEDIA
- PETROCHEMICALS
- GENERAL CHEMICALS
- REFINERY SERVICES

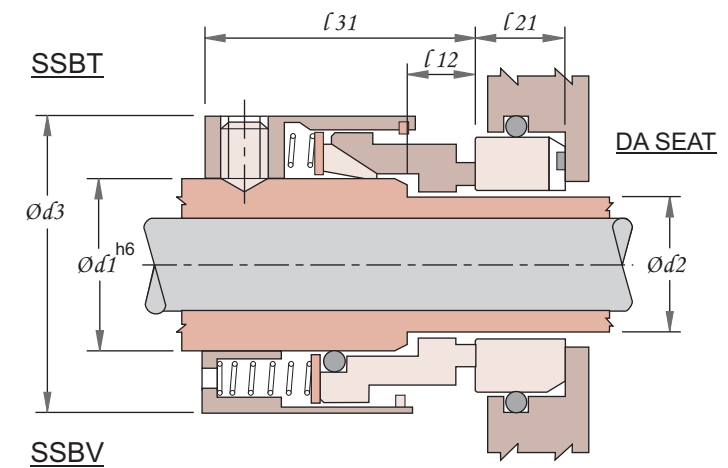
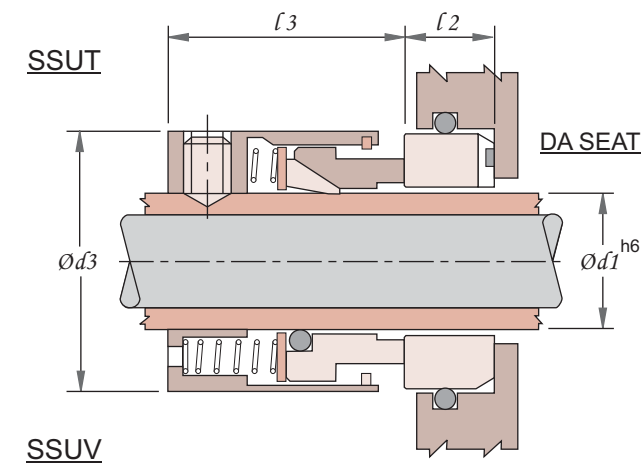

INCH SIZES

SIZE CODE	d1	d2	d3	l2	l21	l3	l31	l12
0190	19.05	15.87	30.2	11.1	11.1	28.6	33.3	7.1
0222	22.22	19.05	33.3	11.1	11.1	28.6	33.3	7.1
0254	25.40	22.22	40.4	12.7	11.1	28.6	33.3	7.1
0285	28.57	25.40	43.6	12.7	12.7	28.6	34.9	8.7
0317	31.75	25.40	48.3	12.7	12.7	28.6	34.9	8.7
0349	34.92	28.57	49.6	12.7	12.7	29.4	36.5	9.5
0381	38.10	31.75	53.2	12.7	12.7	29.4	36.5	9.5
0412	41.27	34.92	56.3	12.7	12.7	29.4	38.1	11.1
0444	44.45	38.10	59.5	12.7	12.7	29.4	38.1	11.1
0476	47.62	41.27	63.5	12.7	12.7	29.4	38.1	11.1
0508	50.80	44.45	66.7	12.7	12.7	29.4	38.1	11.1
0539	53.97	47.62	71.4	14.3	12.7	29.4	38.1	11.1
0571	57.15	50.80	72.2	14.3	12.7	34.1	44.4	12.7
0603	60.32	53.97	76.2	14.3	14.3	34.1	44.4	12.7

DIMENSIONS FOR HIGHER SIZES AVAILABLE ON REQUEST

SIZE CODE	d1	d2	d3	l2	l21	l3	l31	l12
0635	63.50	57.15	79.40	14.3	14.3	34.1	44.4	12.7
0666	66.67	60.32	82.60	15.9	14.3	36.5	46.8	12.7
0698	69.85	63.50	85.70	15.9	14.3	36.5	46.8	12.7
0730	73.02	66.67	93.60	15.9	15.9	36.5	46.8	12.7
0762	76.20	69.85	97.0	15.9	15.9	36.5	46.8	12.7
0793	79.37	73.02	101.6	15.9	15.9	36.5	46.8	12.7
0825	82.55	76.20	104.8	15.9	15.9	36.5	46.8	12.7
0857	85.72	79.37	107.9	15.9	15.9	36.5	46.8	12.7
0889	88.90	82.55	111.1	15.9	15.9	36.5	46.8	12.7
0920	92.07	85.72	114.3	17.4	15.9	38.1	46.8	12.7
0952	95.25	88.90	117.5	17.4	15.9	38.1	46.8	12.7
0984	98.42	92.07	120.6	17.4	17.4	38.1	46.8	12.7
1016	101.6	95.25	123.8	17.4	17.4	38.1	46.8	12.7

ALL DIMENSIONS IN MM

SN SERIES : METRIC SIZES AS PER EN 12756 DIMENSIONS AVAILABLE ON REQUEST

LIMITING PARAMETERS

PRESSURE	TEMPERATURE	SPEED
SSU : UPTO 16 BAR SSB : UPTO 40 BAR	- 20°C TO 280°C DEPENDING ON ELASTOMER	26 m/sec

MATERIALS

METAL PARTS	FACE COMBINATIONS ROTARY STATIONARY	ELASTOMERS
SS316 ALLOY-20 HAST-C	CARBON CERAMIC, SiC, TC GFT CERAMIC SiC SiC	VITON, PTFE EPR, FFKM, SILICON AFLAS

ARRANGEMENTS

